

## Pedals & cranksets

Important information about use, care, maintenance and installation

### Contents

Notes About this User Manual	1
Introduction	1
Before Your First Ride – Determined Use	2
Use, handling of pedals on the bike	2
General Notes on Installation	3
Using a torque wrench	3
TORQUE WRENCH	
Installation of cranksets and chainrings	4
Installation of pedals	5
Adjustment of spring tension of pedals	6
Attaching the pedal cleats to the shoes	6
Maintenance, cleaning and care of pedals	7
Maintenance, cleaning and care of cranksets	8
Warranty Terms	9
Manufacturer's Guarantee	10

## Notes About this User Manual

Pay particular attention to the following symbols:

 This symbol means that your life or health may be in danger unless you comply with provided instructions or carry out prescribed measures.

 This symbol warns you about actions that could lead to damage of property or the environment.

 This symbol indicates there is special information on how to handle the product and may refer you to a specific passage in this manual requiring your special attention.

The possible consequences described above are not repeated every time one of the symbols appears!

## Introduction

Congratulations on your purchase of a RITCHEY component, you have made an excellent choice. At RITCHEY we develop, test and manufacture our products with dedication and strive to uphold the highest standards of quality. Like all high-quality sports equipment, RITCHEY components require careful installation in order to function properly and provide long-term dependability. We recommend that you seek the assistance of a qualified mechanic at your local authorized RITCHEY retail shop. We also recommend using all RITCHEY components to ensure optimal performance and durability. Our precise tolerances are intended to ensure component compatibility and are carefully monitored during production and quality control so that installation will be easy and trouble-free.

This manual contains important notes about use, care, maintenance and installation.

Please read this manual in its entirety, beginning with the general information. Then you can carefully review individual chapters specific to each component you have purchased or intend to use. Doing so will help ensure smooth installation and trouble-free use of the product.

Retain this user manual for your records and future reference. If you sell or loan your component or bike, provide this manual to the new user.

With RITCHEY components, as is the case with all lightweight bicycle products, special care and attention are required for proper installation and use. Materials used by RITCHEY in the manufacture of its components are extremely strong and durable, yet low in weight, making them perfect for high-performance bike riding. It is important to note, however, that all materials, no matter how strong at the outset, are susceptible to wear, tear and fatigue over time, potentially becoming brittle due to extensive exposure to vibrations or impacts. In the event of a crash, significant impact, or undue stress of any kind, the component may not show obvious or visible signs of damage. However, since the material may have sustained undetectable external or internal damage, it is very dangerous to continue using a component after undue stress or a significant impact, because the component could eventually fail as a result, with unforeseeable consequences to your health or well being. After any such occurrence, consult your local RITCHEY dealer to get a professional examination and evaluation of the product.

## Before Your First Ride – Determined Use

RITCHEY road pedals and cranksets (a) are designed for typical use on road and triathlon bikes.

Mountain bike pedals (b) and cranksets are designed for typical use on cyclo-cross, trekking and mountain bikes. They are, however, not built for freeriding, dual slalom, downhill, jumps and comparable uses.

The pedals must not be used with stationary spinning-bikes or ergometers!

The pedals and cranksets are designed to carry a maximum rider's weight of 110 kilograms – luggage, eg backpack, included.

For any RITCHEY clipless pedal, ie, pedal system, you need special cycling shoes that allow for a cleat to be mounted to their sole. Mountain bike and road bike shoes differ in the way the cleats are installed. Shoes designed for road bike pedals cannot be mounted to mountain bike shoes and vice versa.

Make sure to get expert advice when choosing shoes so that they suit the use you intend for them.

Never modify or change your pedal or crankset. Do not file or drill holes in any component as it will compromise their structural integrity and void your warranty.

Be sure to always adjust the pedals in such a way that they firmly engage with the shoes, but allow for them to be released quickly at any time. If they show signs of wear and tear, contact your specialist bike dealer and do not use the pedals and cleats until they have been approved for use (or replaced).

 If you have any questions or concerns, contact your local RITCHEY retailer.

 After a crash, accident or other major impact, replace the pedals and the crank for your own safety.

 If your pedals or cranks make any “creaking,” “crackling” or “cracking” noises, or if there is visible damage, such as notches, tears, dents, discolorations, etc., do not use the bicycle until you have consulted your local RITCHEY dealer, who can check the part carefully and advise whether replacement is necessary.

## Use and handling of pedals on the bike

The pedals make the connection between you and your bike's drive train. Therefore, be sure to always wear suitable shoes, ie, bike shoes with matching cleats.

RITCHEY mountain bike pedals are always designed for the cleats to be pressed in on both sides. With RITCHEY road pedal systems, the engagement mechanism is applied only to one side; because of a special weight distribution, the pedal, however, always falls back to a position allowing for the cleat to engage with it, and you just have to press it in.

Pick up the pedal with the cleat's tip first and then just step onto the horizontally standing pedal body. The shoe will engage with the cleat with a clearly audible and noticeable click (c).

The easiest way of engaging the cleat with the pedal is when the pedal/crank arm is in the lowest position possible (d).

With RITCHEY pedals the connection is released by twisting the heel outward (e).

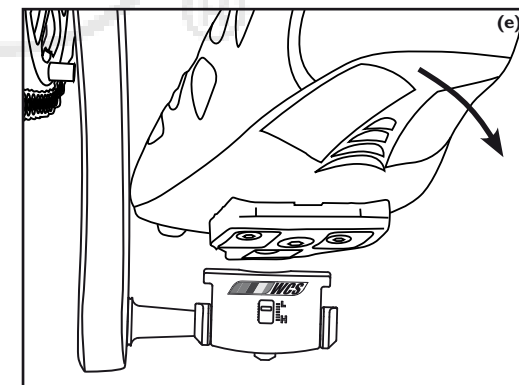
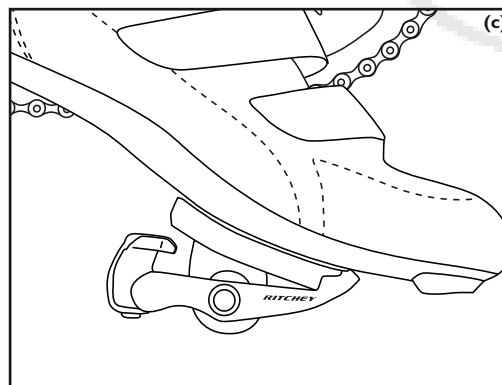
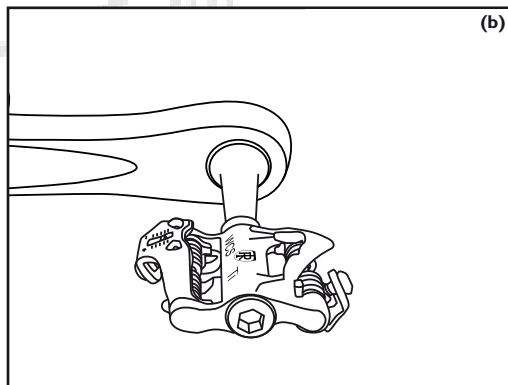
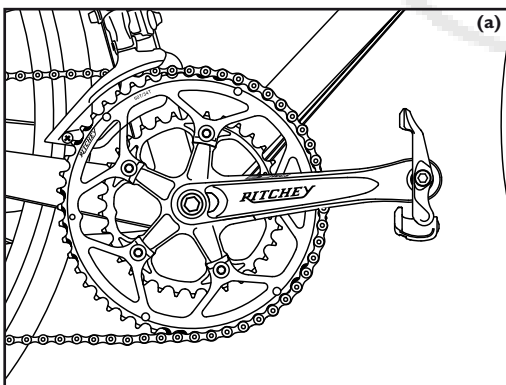
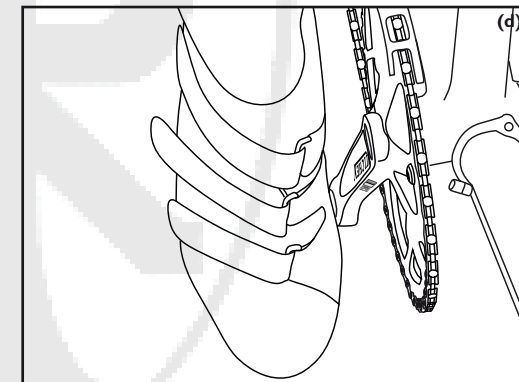

Because of the fixed connection when engaged, the pedal can be pushed and pulled by the fixed foot. This makes it easier to pedal smoothly and considerably improves the transmission of power in comparison with open box clip pedals. Unlike with pedals utilizing toe clips and straps, you can always release the shoe from the pedal by simply twisting your heel outward – this enhances safety, especially in dangerous situations (a).

**i** The spring tension of the pedals can be adjusted. Please read the chapter titled "Adjustment of spring tension".

First practise picking up the pedals as well as engaging and releasing the cleat from the pedal by twisting the foot outward when standing still before refining the technique on a traffic-free space on the street. It is advisable to lean against a wall or something similar when learning these motions for the first time.

On your first test rides or after longer rides with your new pedals, the movement to release the cleat is not yet familiar and therefore may not come automatically. A possible consequence of this is the rider falling to the ground from a standing position which can lead to dangerous collisions with other road users. In order to prevent this from happening, focus on releasing the cleat from the pedal before stopping while you are learning how to use your clipless pedals.

**4** Make sure pedal and sole are always free of dirt and other foreign objects. Otherwise, safe engagement and release cannot be guaranteed leading to the danger of a crash.

**4** Familiarize yourself with the mechanism of your pedal before going on your first ride by practising it with one foot on the ground and the other one engaging and releasing the cleat from the pedal. Then keep practising in a traffic-free space, preferably with soft ground.

## General Notes on Installation

Crankset and pedal installations are jobs for a qualified mechanic. For your own safety, have your local RITCHEY dealer perform the installation and maintenance jobs outlined in this manual. Each of the following instructions must be followed precisely. Failure to observe these guidelines can cause a component to fail, resulting in a crash and/or injury.

Installation of parts with differing tolerances can cause problems due to incompatibility or poor fit, and can lead to component failure, as well as accident or injury.

We recommend using RITCHEY pedals with a RITCHEY crankset and vice versa, because they are designed to fit and function as an integrated whole. If you choose to use a part from another manufacturer, consult their product documentation to ensure proper fit and usability with a RITCHEY component.

RITCHEY assumes no responsibility for problems resulting from a RITCHEY component being used with a part from another manufacturer.

If you are unsure about a RITCHEY or a non-RITCHEY component, have your local RITCHEY dealer examine the problem in order to see whether the issue can be remedied and how.

**4** Once it is determined that a component is damaged, it should not be used under any circumstances.

**4** Stop using the bicycle until the part has been replaced! If there is any doubt, we recommend replacing the part.

## Using a torque wrench

To achieve long lasting and problem free clamping of parts, RITCHEY considers the use of a torque wrench (b) absolutely necessary.

**4** Loose or overly tightened bolts can lead to failure and therefore to an accident. Adhere to torque specifications carefully. If you do not have access to a high-quality torque wrench, see your local RITCHEY dealer.

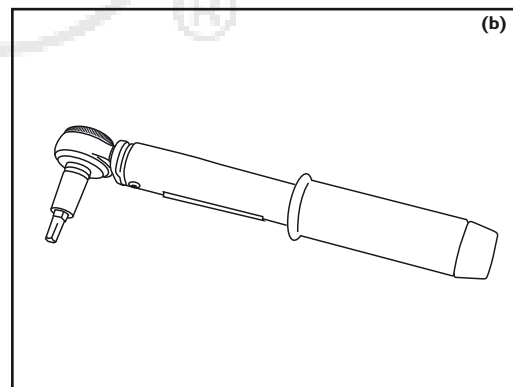
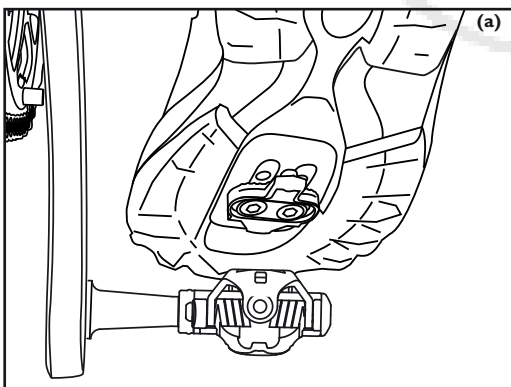

## TORQUE WRENCH

### Installation of cranksets and chainrings

Ask your bike dealer for support when adjusting and mounting your crankset for the first time! If you want to try it yourself, please read the following chapters carefully.

Note that RITCHEY cranks are provided for Shimano octalink bottom brackets. Grease the spindle of the bottom bracket (c) and the crank bolts (d). Mount the cranks at the spindle carefully and take care that the teeth fit together properly.

Tighten the crank screws only after both parts fit together securely. Also take special note of the bottom bracket manufacturer's instructions.

After mounting the cranks and tightening the crank bolts to the correct bolt torque with a torque wrench, check that both the crank ends and the chainrings have enough clearance in relation to the chainstays (e).

RITCHEY cranks always come with chainrings mounted and ready to be installed to the bike. If you want to mount new chainrings, we strongly recommend you use RITCHEY original spare parts.

Pay attention to the correct position of the chainrings during installation. The pin of the big chainring must be behind the crank arm. Take care that the smaller rings are positioned so that the chain cannot wedge in between them and the inside of the crank arm.

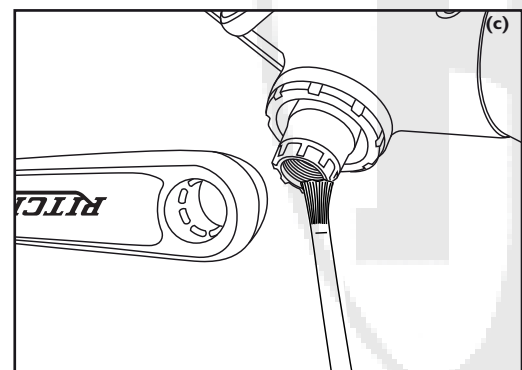

Grease and mount the hollow bolts by hand and ensure that the chainrings are round. Then tighten the bolts to the recommended torque of 7-9 Nm / 62-80 In.lb (f).

**4** Never exceed the torque indicated! Check the torque after the first 200 to 400 kilometers (120-240 miles) and then every 2,000 kilometers (1,200 miles). Loose bolts or pedal axles can cause accidents and injury.

### Technical data:

Bolt-circle road	130 or 110 mm
Bolt-circle mountain	104/64 mm
Recommended chain line road	43.5 mm
Recommended chain line mountain	50 mm
Pedal thread	9/16" x 20TPI
Recommended torques:	
Chain wheel bolts	7-9 Nm/62-80 In.lb
Crank bolts	30-40 Nm/265-364 In.lb
Pedals spindles	35-40 Nm/310-364 In.lb
Pedal cleats on sole	4-6 Nm/35-53 In.lb

**i** All torques are guide values only. Also observe the instructions provided by other component's manufacturers! If you have any questions, please ask your RITCHEY dealer.

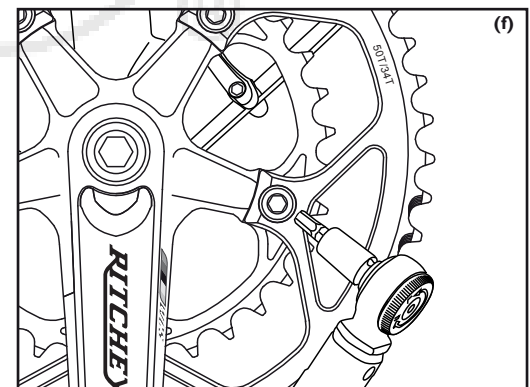
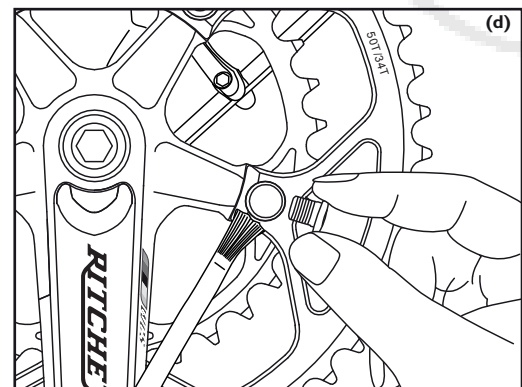
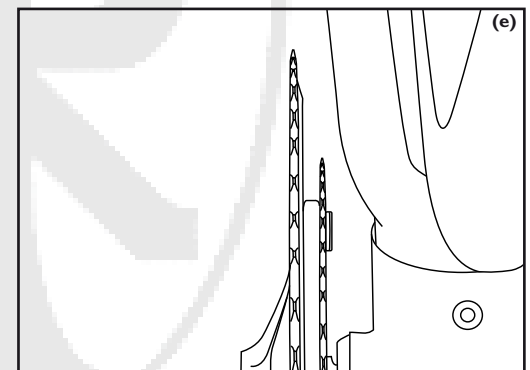

## Installation of pedals

Always ask your bike dealer for support when adjusting and mounting your pedals for the first time! If you want to adjust or mount your pedals yourself, please read the following chapters carefully.

Before installing the pedals, make sure the pedal thread matches the crank. Older bikes, but also BMX bikes, do not have the usual standard thread 9/16" x 20TPI. In case of doubt, ask your bike dealer for advice.

Grease the crank and pedal threads as well as the pedal axle contact faces with fitting lubricant (a).

Position the axle of the right pedal with your fingers and screw it in several turns clockwise before tightening it with a pedal wrench, ie. a 15 mm open-jaw wrench (b).

The left pedal has a left-hand thread. Position the axle with your fingers and screw it in counterclockwise. Tighten the pedal with a pedal wrench (c).

The torque recommended is between 30-35 Nm/265-310 In.lb.

 Some crank manufacturers attach washers to their cranks. Use these according to the manufacturer's instructions if necessary.

 Never exceed the torque indicated! Check the torque after the first 200 to 400 kilometers (120-240 miles) and then every 2,000 kilometers (1,200 miles). Loose pedal axles can cause accidents and injury.

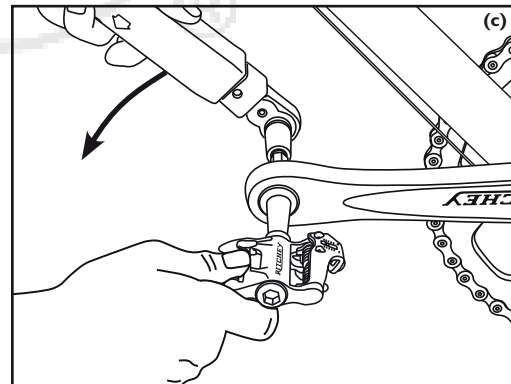
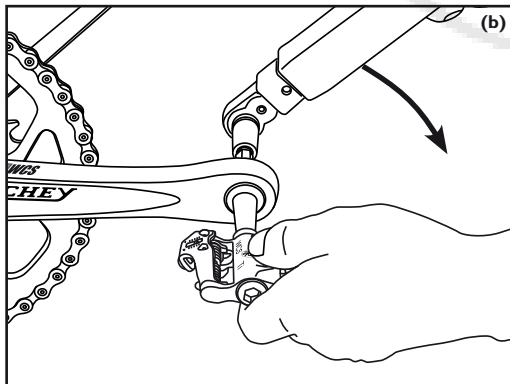
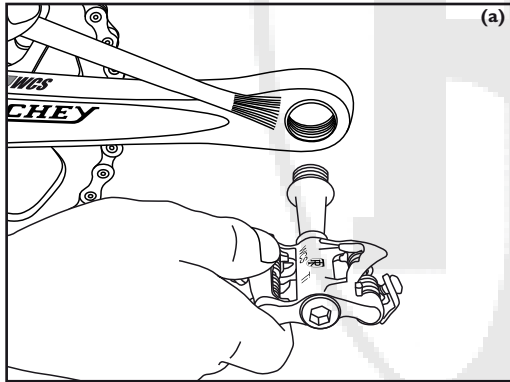

## Adjustment of pedal spring tension

The spring tension of RITCHEY pedal systems can be adjusted with an Allen key.

Adjust the spring tension of road pedals with the bolt on the bottom of the pedal (d).

Adjust the spring tension of mountain bike pedals with the bolt in the rear of the pedal (e).

Adjust the spring tension so that you can always release the cleat from the pedal. At the beginning, it is advisable to choose a light spring tension until you are more familiar with the release mechanism. After getting used to the system, a tighter spring tension offers the advantage of more security. Try tightening the tension in small increments and practise engaging and releasing from the pedal as described above after every adjustment.

 A too tight spring tension can lead to the engagement mechanism not releasing the shoe anymore – be aware!

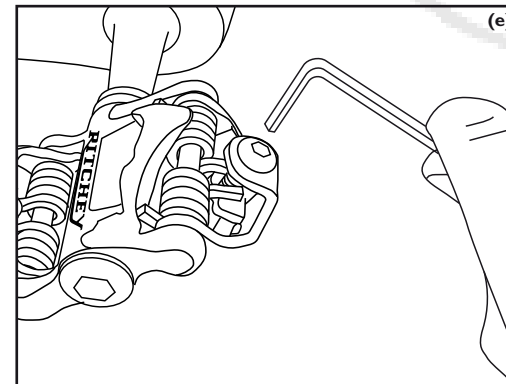
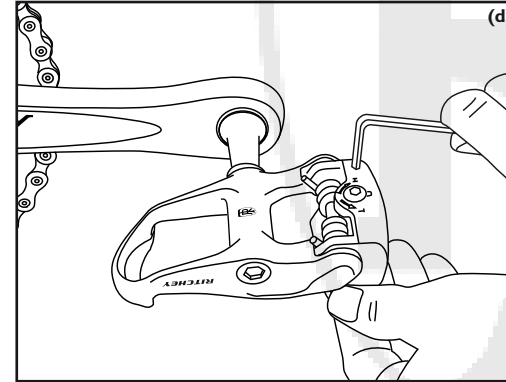

## Attaching the pedal cleats to the shoes

First of all, check whether the holes on the body of the cleat are compatible with the drilled holes in the sole of your bike shoe. It is recommended to have your cleats fit by your RITCHEY dealer if you are doing this for the first time.

Generally speaking, the triangular (ie. pointed part) of the cleat should always point to the tip of the shoe (f). Cleats and soles have a certain adjustment range. The cleats' position therefore can be adjusted to suit your proportions and fit needs.

Attach the cleats to the shoe so that the ball of the foot is positioned over the pedal axle (g).

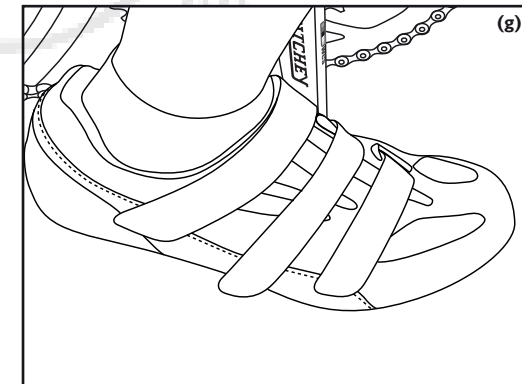
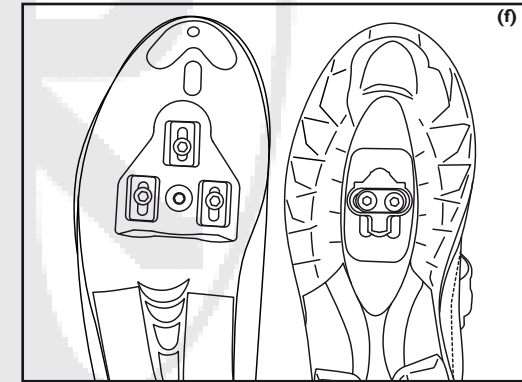



The foot should be in its natural position when pedalling. With most people the heel then points slightly inwards (a).

Determine the cleat position that suits you best by loosening and shifting the cleat on the shoe several times, if necessary.

Finally tighten the cleats' bolts with a torque wrench to a torque of 4 to 6 Nm/35 to 53 In.lb (b).

 Be sure to also read the shoe manufacturer's manual for additional cleat mounting/fitting instructions.

 Be sure the shoe you choose is compatible with your RITCHEY pedals. Not all shoes and pedals work perfectly together. Specifically, there are key differences between mountain bike and road bike shoes. If in doubt, seek advice from your RITCHEY dealer.

 Only use pedal systems which engage and release smoothly. If the pedal does not work properly or if the cleat is heavily worn, there is the danger of falling as the shoe may release from the pedal inadvertently. In some cases it also may happen that the shoe cannot properly release anymore or only with some difficulty.

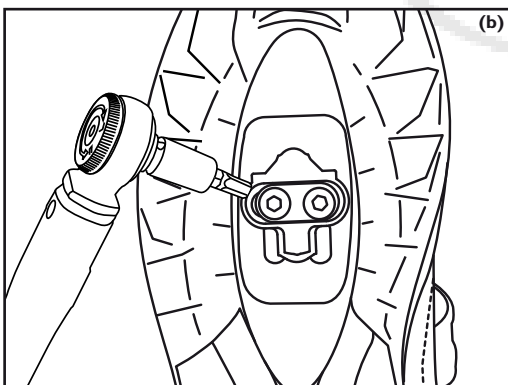
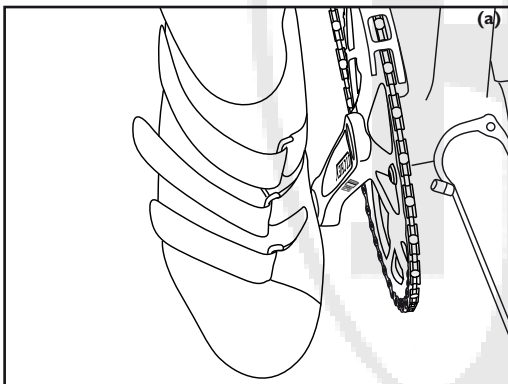

## Maintenance, cleaning and care of pedals

The pedals are delivered ready to mount except for the individual adjustment of spring tension. The pedals' bearings are greased and adjusted and require very little maintenance. Do not clean the pedals with a strong jet of water as this damages the inner grease fill and may contaminate the bearings. Regularly check the pedals for play in the bearings or, if they rotate with difficulty. If this is the case, please contact your RITCHEY dealer for proper adjustment.

Clean your pedals with water and a soft cloth. If necessary, use a non abrasive soap to remove grime. Regularly clean the engagement mechanism, ie, before every ride if necessary, so that it is free of dirt and mud. Grease the exposed springs and bearing points of mobile parts with oil, ie, once a month (c).

Only use gasoline based solvents for cleaning tough stains like oil or grease from hard surfaces. Do not use degreasing agents, which contain organic solvents (ie, acetone, trichloroethylene, methylene, etc.). Chemicals of this sort may damage the finish or substructure of the material.

After drying your bike you can apply a wax based polish (f) to painted, carbon and metal surfaces. After the wax has dried, polish the parts. With this treatment your pedals will keep their nice finish for years.

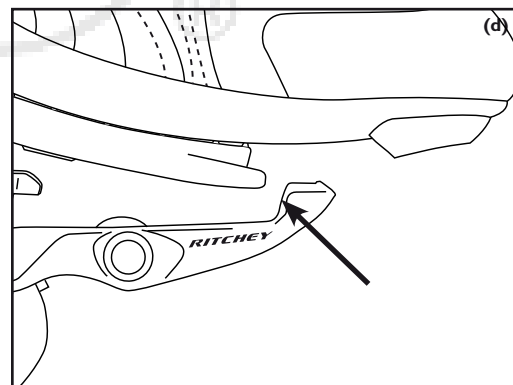
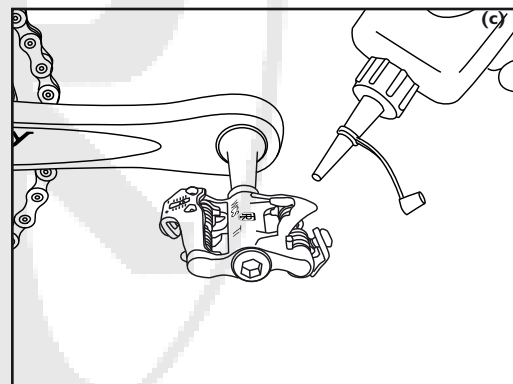

 While cleaning look for cracks, scratches, dents as well as bent or discoloured material. If you think there may be a problem, see your local RITCHEY dealer. Have damaged or defective components replaced immediately to ensure safe use.

Be sure the bolts for the cleats are always tightened to proper torque tension. Disengaging from the pedal is almost impossible with a loose cleat – putting the rider in danger of crashing!

 Check the torque of the cleat bolts and pedal axles in the cranks after the first 200 to 400 kilometers (120-240 miles) and then every 2,000 kilometers (1,200 miles). Loose pedal axles and cleats can cause accidents.

Creaking and squeaking of cleats can be fixed by applying some grease to the contact points between cleat and pedal (d).

Cleats in use are subject to wear. If they do not engage or release, or if they only engage or release with ease or with much difficulty, they will have to be replaced.

Synthetic cleats need to be inspected for wear regularly. If the cleats are getting very thin in the front or back and appear to have a crescent-shaped taper, they will have to be replaced immediately to ensure safety. A wobbly feeling of the cleat where it meets the pedal hints that the cleat or shoe sole is worn (e).

Replace the cleats only with original RITCHEY spare parts. Cleats from other manufacturers can lead to improper working of the mechanism preventing the cleat from proper release – and leading to the danger of a crash.

Be sure to check the spring tension after changing the cleats and adjust them anew if necessary.

 If a noise occurs from somewhere around the pedals, grease the contact points between cleats and pedals. If this does not solve the problem, it may be a sign of wear.

 Do not ride with worn cleats, the shoe might release unexpectedly.

 Be sure that pedals and soles are always free of dirt or other foreign objects, keep the clean and regularly grease the engagement mechanism with oil.

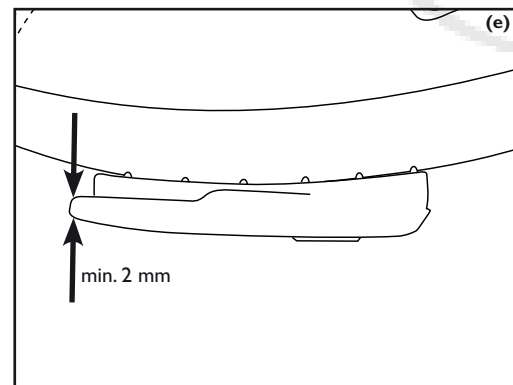

## Maintenance, cleaning and care of cranksets

The cranksets are delivered ready to mount. Do not clean the cranks with a strong jet of water as this damages the inner grease fill of the bottom-bracket bearings. Regularly monitor the chainring bolts and crank bolts to ensure they are tightened to the recommended torque.

Check the chainrings for wear, if you install a new chain. A new chain might otherwise slip at the freehub teeth engagement point, resulting in a crash or accident.

 Check the tightening torque of the chainring bolts and crank bolts after the first 200 to 400 kilometers (120-240 miles) and then every 2,000 kilometers (1,200 miles). Loose chainring bolts and crank bolts can cause accidents.

Clean your crankset with water and a soft cloth. If necessary, use a non abrasive soap to remove grime. Only use gasoline based solvents for cleaning tough stains like oil or grease from hard surfaces. Do not use degreasing agents, which contain organic solvents (ie, acetone, trichloroethylene, methylene, etc.). Chemicals of this sort may damage the finish or substructure of the material.

After drying your bike you can apply a wax based polish to painted, carbon and metal surfaces. After the wax has dried, polish the parts. With this treatment your crankset will keep its nice finish for years (f).

 While cleaning, look for cracks, scratches, dents, as well as bent or discoloured material. If you think there may be a problem, see your local RITCHEY dealer. Have damaged or defective components replaced immediately.

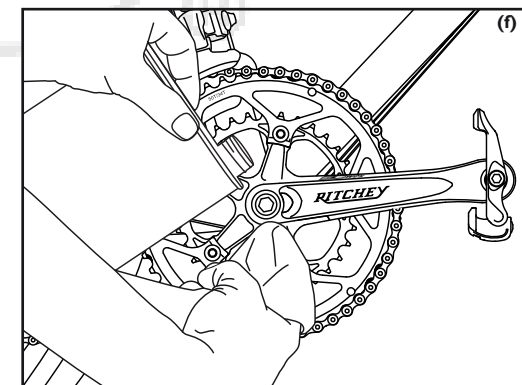

## Warranty Terms

Under European consumer law, the purchaser has full statutory warranty rights within the first two years from date of purchase. In North America, these rights apply to the first year from the date of purchase. According to these laws, your RITCHEY dealer is responsible for ensuring the product is free of defects that could cause premature wear from normal use.



The new European warranty law is valid in the countries where European (EU) regulations apply! Please ask your dealer about the regulations in your country!

Warranty claims will only be accepted if the bicycle has been used solely for its intended purpose (see section, "Before your first ride").

It does not cover damage resulting from wear, neglect (insufficient care and maintenance), accidents, overstress caused by over-tightening, incorrect installation, improper treatment or as a result of modifications made to the component.

Be sure to strictly follow all assembly instructions in this manual precisely, as well as all additional instructions provided by the manufacturers of products used in conjunction with RITCHEY products, especially bolt torque specifications and prescribed maintenance. Observe all instructions with regard to procedures and verification processes listed in this manual, as well as any other instructions that may be included in the delivery of RITCHEY products. Also adhere strictly to any and all instructions pertaining to the replacement of safety relevant components, such as seat posts, stems, etc.

Your direct contact with regard to all issues outlined in this manual and corresponding instruction is your local RITCHEY dealer, who should be qualified to answer your questions. In order to obtain assistance from a RITCHEY dealer, you may be required to show your receipt.

**YOU MUST CONTACT YOUR RESELLER, IF YOU HAVE A WARRANTY ISSUE OR CONCERN, I.E. THE RITCHEY DEALER WHO SOLD YOU THE BICYCLE COMPONENT IN QUESTION.** RITCHEY has exclusive agreements with all of its reseller partners to service potential warranties. If you purchase a RITCHEY product from an unauthorized reseller (e.g.: an auction site on the internet), you have no recourse through RITCHEY or any of its authorized resellers, so you must seek support from the reseller who sold you the product.

## A Note on Wear

Bicycle components are subject to wear due to normal and proper use. The rate of wear will depend on care and maintenance, the bike's usage and the environment it is exposed to, such as rain, mud, dust, and sand. Some components require regular care and maintenance, but despite the best maintenance program, all components will eventually reach the end of their serviceable life depending on conditions and intensity of use.

The following RITCHEY part is especially subject to wear due to the nature of its intended use and not covered for wear under this warranty:

The cleats of pedals are subject to wear from the lubricants in the bearings of pedals and the chainrings of cranksets are subject to abrasion from the chain and road grit.

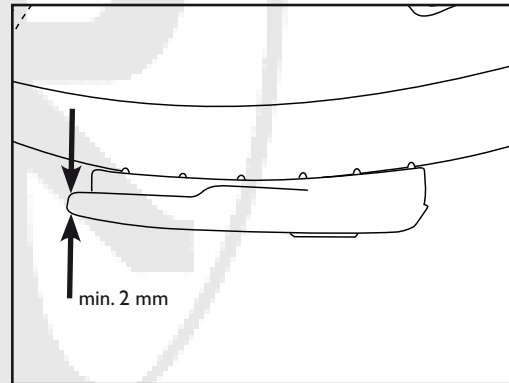

## Manufacturer's Guarantee

RITCHEY products have been developed and manufactured with great care and have gone through numerous testing controls. Our products are examined as part of our internal quality control process to meet strict standards, as well as by external, neutral test laboratories.

For the EU market we grant, independent of legal regulations, a voluntary guarantee that your RITCHEY product is free of manufacturing and workmanship defects for two years from the date of purchase.

For the North American Market we grant, independent of legal regulations, a voluntarily guarantee, that your RITCHEY product is free of manufacturing and workmanship defects for one year from date of purchase.

This manufacturer's guarantee only applies to claims made by the initial buyer, who must present the purchase receipt with date of purchase, dealer address and model number. Guarantee claims will only be accepted, if the bicycle has been used in accordance with the intended use of RITCHEY products.

This guarantee does not cover damage resulting from:

- wear
- neglect (insufficient care and maintenance)
- accidents
- overstress caused by over-tightening
- incorrect installation or improper treatment
- changes or modifications to the component



The instructions in this and all RITCHEY manuals are carefully designed to maximize the life of RITCHEY products. Any guarantees are void if installation instructions are ignored and/or if regular inspection and maintenance intervals are neglected.

In the case of a warranty claim, RITCHEY reserves the right to provide all or part of the current successor model in an available colour – or if such part is not available, a higher grade model – to remedy the claim. The guarantee does not cover assembly, refitting costs or any new accessories that may be required (ie, different dimension parts).

The guarantee does not cover labor and transport costs, nor does it cover follow-up costs resulting from defects.

Your direct contact for any issue should be your RITCHEY dealer/ reseller, who is authorized to respond to your inquiries.

Find contact information for your reseller or national distributor at [www.ritcheyllogic.com](http://www.ritcheyllogic.com).

**RITCHEY International**  
Via Cantonale 2  
CH- 6916 Grancia-Lugano

**RITCHEY Design Inc. Taiwan Branch**  
22-1, #123 Chungang Rd. Sec 3  
Taichung 407  
Taiwan R.O.C.

If you have any question, please ask your national distributor. You will find a distributors list at [www.ritcheyllogic.com](http://www.ritcheyllogic.com).

**RITCHEY Corporate HQ's**  
620 Spice Island Drive  
Sparks, NV 89431

**RITCHEY Design Inc.**  
Sales & Warranty Office  
575 Old County Road  
San Carlos, CA 94070

Technical details in the text and illustrations of this manual are subject to change.

© No part of this publication may be reprinted, copied or transmitted by hand or with mechanical or electronic systems or used for an another business purpose without prior written permission.

Concept and text: Zedler Engineering [www.zedler.de](http://www.zedler.de)

1st edition Octobre 2007

