



BICYCLE COMPONENTS

Carbon Fork Owner's Manual

Ritchey Bicycle Components
Sales and Warranty Office
575 Old County Road, San Carlos, CA 94070
www.ritcheylogic.com

Thank you for purchasing a Ritchey Carbon Fork. This fork has been manufactured using a carbon molding technique that ensures high rigidity, strength and safety. In order to achieve the highest performance, read the precautions before using.



WARNING

Means: Failure to observe this warning can result in serious injury or death.



CAUTION

Means: Failure to observe this warning can result in injury and/or product damage.



Forbidden



Be particularly careful.

PRECAUTIONS IN USE



WARNING



Ensure that fork steerer tube cutting, assembly, parts replacement or other servicing is carried out by qualified personnel. Unauthorized servicing invalidates your warranty.



In the case of strong impact - due to collision, falling, crashing, riding over deep holes or other causes, the fork could be damaged and break. Immediately contact Ritchey or your retailer to evaluate if the fork has been damaged and that there are no anomalies. Even an apparently superficial crack may damage the carbon fibers, compromising the user's safety.

NAME OF PART AND SIZE

Fork blade/Crown dimensions

FORK	1" Road	1-1/8" Road	Cyclocross	MTN
A. Rake	45mm	43/45mm	45/48mm	48mm
B. Brake length	354mm	354mm	N/A	N/A
C. Axle to Crown	368mm	368mm	390/400	409
D. Dropout Width	100	100	100	100
E. Brake Hole Position	13	11	N/A	N/A
F. Crowl Race Diam.	26.4	30	30	30

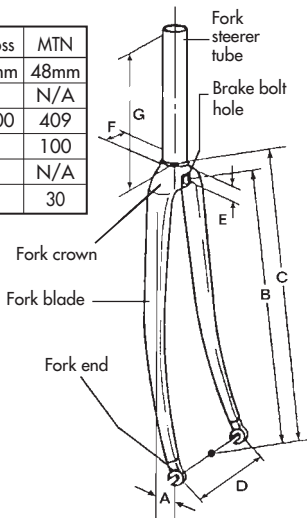

Steerer tube dimensions

Steerer Tube	Ahead
G. Column length	300
outer/inner for 1" fork	25.4 - 19.0
outer/inner for 1 1/8" fork	28.6 - 25.4

PRECAUTIONS IN MAINTENANCE AND CLEANING

To clean surfaces of dirt, wipe first with a soft piece of cloth then remove oil by wiping with a petroleum based cleaner, do not use solvents. To bring out the shine of the paint, it is recommended to use a non-abrasive silicon polisher such as car wax. Do not use an abrasive wax as it can damage the paint



CAUTION



Do not use degreasing agents which contain organic solvents (i.e: MEK, acetone, trichloroethylene, methylene chloride, toluene, xylene, etc.) These chemicals can deteriorate the shine of the paint.

TO DEALERS AND USERS

PRECAUTIONS FOR ASSEMBLY AND ADJUSTMENT

- To press fit the headset crown race

Carefully check that no dirt or other foreign matter that may compromise the fitting has adhered to the contact surface of the crown race. Also verify that the crown race is the specified dimension.

In the case of forks with an aluminum crown race, the thickness of the paint finish on the press-fit part of the crown race may make assembly difficult. Very fine grain sandpaper may be used to 'clean' the excess paint from the press fit area.

Do not, under any circumstances, use files or other tools which may remove the fork material along with the paint, thus compromising the tightness of the fork itself.



WARNING



Ensure that the headset crown race press fitting and steerer tube cutting is carried out by qualified personnel. Unauthorized servicing invalidates your warranty.



Do not service the press fit part of the crown race in any way. In case of problems, immediately contact the place of purchase.



Tampering or unauthorized modification of the product will automatically invalidate the warranty.

Proper steerer tube height

For 'ahead' type carbon steerer tube (w/o threads), check that the handlebars are at the desired height then cut the steerer tube using a saw suitable for cutting composite fibers. To prevent damage to the fibers and to leave a minimum margin for the placement of spacers for future adjustments, we recommend cutting the tube using two cuts from opposite directions, meeting at the center.

CF STEERERS



WARNING

CF STEERERS

CF STEERERS



For Forks with Carbon Fiber Steerers use only original Ritchey internal uniform action expanders. The use of non-original expanders, to adjust the headset voids the warranty.



Do not use the star nut included with your headset in CF Steerers. It can damage the carbon fibers inside the steerer tube.



OK



NO



The position of the top of the compression device should not be deeper than 3mm from the top of the stem. It is preferred to leave excess length on the steerer tube and add a spacer above the stem.

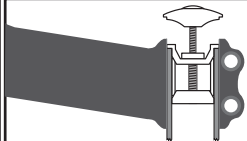

Ritchey carbon forks are provided with 2 different styles of compression devices. The silver compression device is fixed using an 8mm allen while the black is fixed using a 6mm allen. To properly install, remove the top cap and bolt using a 5mm allen wrench. Install the expander until the top sits flush with the carbon steerer tube. Tighten until snug using the appropriate allen wrench. Install the stem followed by the top cap and adjust your headset based on the manufacturer's recommendations.

ASSISTANCE SERVICE AND GUARANTEE



Every effort has been made to ensure this product is top quality. Should you notice any defects or malfunction, either visually or during use, immediately contact the place of purchase or contact Ritchey directly.



Ritchey shall be released from any responsibility, either civil or penal, resulting from damages to third parties incurred by the Ritchey product, should the conditions in point 3, which lead to invalidation of the warranty, be verified.

WARRANTY CONDITIONS

This product has been designed, manufactured and tested with the utmost care using very severe quality and safety standards. Ritchey and its distributors shall replace this product free of charge for defects as per the specified Warranty Provisions should the defect be clearly attributable to Ritchey or Ritchey distributors. An incomplete warranty form or incorrect information may invalidate the warranty.

1. Warranty duration.

This warranty shall be valid for a period of one year from the date of purchase, however this shall not apply in the cases listed in point 3 below.

2. Conditions and Procedures for Receiving Warranted Servicing.

- To receive servicing present both the warranty and the defective product to the place of purchase. If the warranty is not present or if the term of one year from date of purchase, indicated in the same, has expired, any repairs and/replacement shall be subject to billing.
- Altering any of the information on the warranty immediately invalidates the warranty.
- This warranty is applicable in the United States for direct sales, everywhere in the world for alternative distribution through authorized Ritchey distributors.
- If anything remains unclear about this warranty, contact the nearest Ritchey dealer or the regional distributor.

3. The warranty will be invalidated in the following cases:

- Incorrect assembly of the product.
- Breaking or damage following an accident, shock or crash.
- Poor maintenance.
- The use of non-original expanders.
- Use of the fork for purposes other than those for which it has been designed and constructed.
- Falsification or modification of the warranty certificate.

The warranty does not cover minor noise and/or vibrations.



- Check the warranty to ensure it has been completely filled in before accepting this product.
- Keep this warranty card in a safe, convenient place. A second copy shall not be issued in the event of loss.

For more information regarding Ritchey warranty and specific warranty information for those located in the EU, please visit ritcheylogic.com



BICYCLE COMPONENTS

Warranty Card
Mail this with a copy of your receipt

Name _____

Address _____

Phone _____ Email _____

Date of Purchase _____ Model _____

Serial # _____

Dealer/Retailer Name _____

Dealer/Retailer Address _____

Please mail this along with a copy of your receipt to
Ritchey Design Inc., Sales and Warranty Office
575 Old County Road, San Carlos, CA 94070



BICYCLE COMPONENTS

Warranty Card

Keep this copy with your original receipt

Name _____

Address _____

Phone _____ Email _____

Date of Purchase _____ Model _____

Serial # _____

Dealer/Retailer Name _____

Dealer/Retailer Address _____

Please keep this Warranty Card along with your original receipt.

Do Not Mail this to Ritchey.